



We Tame Photons to Work for You!



Products > LEDs > Thru-Hole > Rectangular > 2mm x 5mm > Standard



### Features / Options

- ▶ State-of-the-Art, High Brightness Chip Technology
- ▶ Choice of Colors and Lens Finishes
- ▶ Lead Frame / Lens Casting Reliability
- ▶ Easy-to-Solder Leads, Tin Finish
- ▶ Available Bulk or on Tape and Reel
- ▶ Lead Trimming and Forming Available
- ▶ Custom Shapes, Easily Tooled, Low Minimum

### Applications / Uses

- ▶ Board or Panel Indication or Illumination
- ▶ Annunciator and Control Panels
- ▶ Telecom Switches and Central Station Equipment
- ▶ Large Panel Indicators

Part Number:	Brightness	Dice Material	Emitted Color	Peak Wavelength	Epoxy Lens	Operating Typ Vf (V)	Intensity Typ, mcd @ 20 mA	View Angle 2x Theta		
SSL-LX2573AD	STANDARD	GaAsP	Amber	605	Diffused	2.1	5	110		—
SSL-LX2573GD	STANDARD	GaP	Green	565	Diffused	2.1	10	110		—
SSL-LX2573HD	STANDARD	GaP	Red	700	Diffused	2.0	30	110		—
SSL-LX2573HGW	STANDARD	GaP	Red/Green	700	White Diffused	2	6	110		—
SSL-LX2573ID	STANDARD	GaAsP	Red	635	Diffused	2.0	10	110		—
SSL-LX2573OD	STANDARD	GaAsP	Orange	630	Diffused	2.1	15	110		—
SSL-LX2573PGD	STANDARD	GaP	Green	555	Diffused	2.1	6	110		—
SSL-LX2573SGD	STANDARD	GaP	Green	565	Diffused	2.1	12	110		—
SSL-LX2573SID	HIGH	AllnGaP	Red	636	Diffused	2.0	100	110		—
SSL-LX2573SOD	HIGH	AllnGaP	Orange	610	Diffused	2.0	100	110		—

UNCONTROLLED DOCUMENT

PART NUMBER  
SSL-LX2573ID

REV.  
C

REV.	E.C.N. NUMBER AND REVISION COMMENTS	DATE
A	E.C.N. #10113.	10.3.96
B	E.C.N. #10BRDR. & REDRAWN IN 3D.	6.15.01
C	E.C.N. #11248.	8.12.05

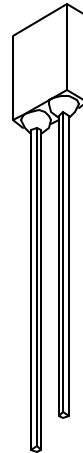
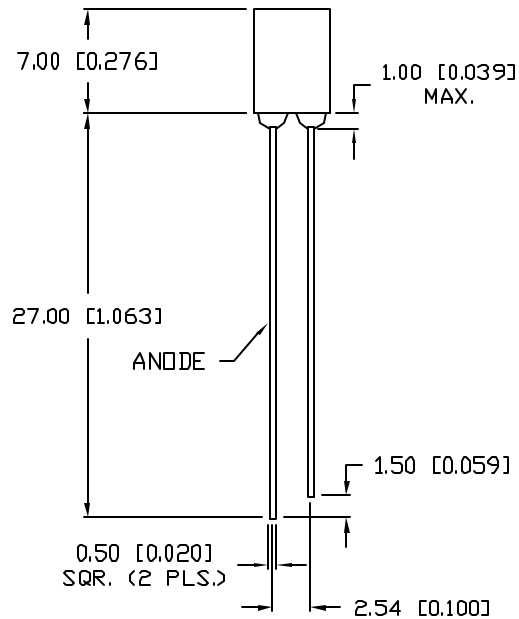
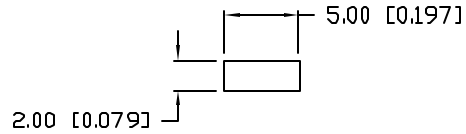

ELECTRO-OPTICAL CHARACTERISTICS  $T_A=25^\circ\text{C}$   $I_f=20\text{mA}$

PARAMETER	MIN	TYP	MAX	UNITS	TEST COND
PEAK WAVELENGTH		635		nm	
FORWARD VOLTAGE		2.0	2.5	V <sub>f</sub>	
REVERSE VOLTAGE	5.0			V <sub>r</sub>	$I_f=100\mu\text{A}$
AXIAL INTENSITY		10		med	$I_f=20\text{mA}$
VIEWING ANGLE		110		2x theta	
EMITTED COLOR:	RED				
EPOXY LENS FINISH:	RED DIFFUSED				

LIMITS OF SAFE OPERATION AT 25°C

PARAMETER	MAX	UNITS
PEAK FORWARD CURRENT*	150	mA
STEADY CURRENT	30	mA
POWER DISSIPATION	105	mW
DERATE FROM 25°C	-1.2	mW/°C
OPERATING, STORAGE TEMP.	-40 TO +85	°C
SOLDERING TEMP.	+260	°C
2.0mm FROM BODY		3 SEC. MAX

\*  $t < 10\mu\text{s}$

\*UNLESS OTHERWISE SPECIFIED TOLERANCES PER DECIMAL PRECISION ARE: X=±1 (±0.039), X.X=±0.5 (±0.020), X.XX=±0.25 (±0.010), X.XXX=±0.127 (±0.005), LEAD SIZE=±0.08 (±0.002), LEAD LENGTH=±0.75 (±0.030), MIN= <sup>+0.00</sup> <sub>-0.00</sub> DECIMAL PRECISION, MAX= <sup>+0.00</sup> <sub>-0.00</sub> DECIMAL PRECISION



UNCONTROLLED DOCUMENT

REV. C	PART NUMBER SSL-LX2573ID	CONFIDENTIAL INFORMATION THE INFORMATION CONTAINED IN THIS DOCUMENT IS THE PROPERTY OF LUMEX INC. EXCEPT AS SPECIFICALLY AUTHORIZED IN WRITING BY LUMEX INC, THE HOLDER OF THIS DOCUMENT SHALL KEEP ALL INFORMATION CONTAINED HEREIN CONFIDENTIAL AND SHALL PROTECT SAME IN WHOLE OR IN PART FROM DISCLOSURE AND DISSEMINATION TO ALL THIRD PARTIES.	
2mm x 5mm RECTANGULAR, 635nm RED LED, RED DIFFUSED LENS.		RELIABILITY NOTE OUR MANY YEARS OF EXPERIENCE DATA ACCUMULATION INDICATE THAT SOLDER HEAT IS A MAJOR CAUSE OF EARLY AND FUTURE FAILURE. PLEASE PAY ATTENTION TO YOUR SOLDERING PROCESS.	DRAWN BY: BC CHECKED BY: APPROVED BY: DATE: 2.12.95 PAGE: 1 OF 1 SCALE: N/A